

REVISION

DATE



LAPP INSULATOR Co.
LEROY, N.Y. 14482



No. SDJ-317053 & -70

DATE 3-31-95

SCALE 1/4

TITLE SOLID PEDESTAL POST

DWN. D. Connolly

CHK.

APP.

BK.No. 84F

REF. TR53

4 TAPPED HOLES
5/8-11 +.015 OVERSIZE
.75 (19) FULL THREAD
ON 5.0 (127) BOLT CIRCLE

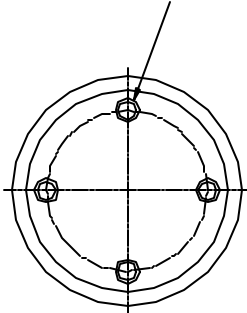

ELECTRICAL PATH DISTANCE

LEAKAGE DISTANCE, in. (mm) 37 (940)

MECHANICAL VALUES

CANTILEVER STRENGTH, lbs. (kN)
UPRIGHT 400D (17.8)
INVERTED 250D (11.1)
TENSION STRENGTH, LBS. (kN) 2000D (88.9)
TORSION STRENGTH, IN.-LBS. (kNm) 4000D (4.5)
COMPRESSION STRENGTH, LBS. (kN) 6000D (266.9)

ELECTRICAL VALUES

CRITICAL IMPULSE FLASHOVER, POS., KV. 280
LOW FREQUENCY WET WITHSTAND, KV. 100
IMPULSE WITHSTAND, KV. 250

NOTES:

1. DIMENSIONS ARE IN INCHES {MILLIMETERS}
2. ALL FERROUS PARTS ARE HOT DIP GALV. PER ASTM A153

ASSEMBLY NO.	GLAZE COLOR
J-317053	CHOCOLATE
J-317053-70	LIGHT GRAY No.70

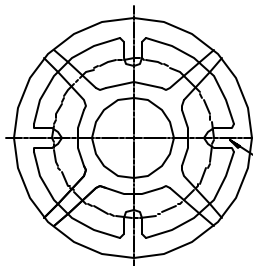
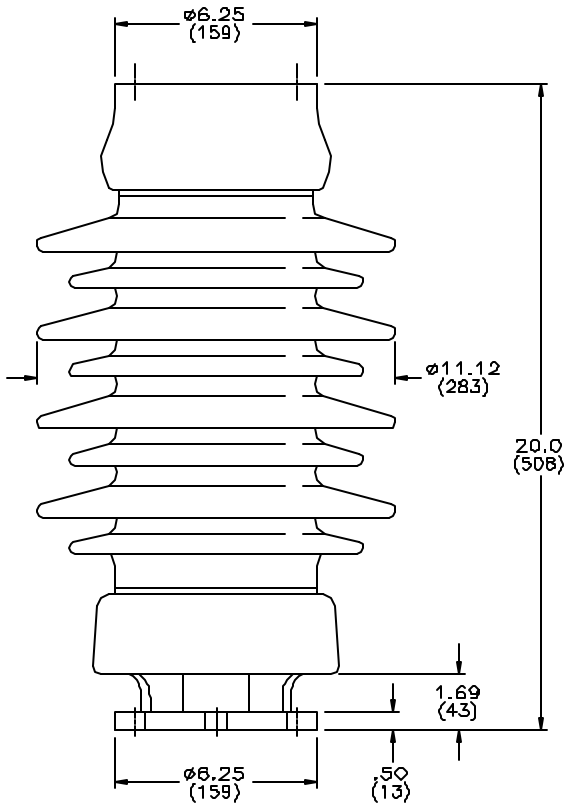

4 SLOTS
.69 (17) WIDE ON
5.0 (127) BOLT CIRCLE

NOTE TO PURCHASER
ALL SALES OF LAPP PRODUCTS ARE
SUBJECT TO OUR STANDARD TERMS
AND CONDITIONS AND THE LIMITED
WARRANTIES THEREUNDER.